

ADRES DO KORESPONDENCJI:

P.P.U. „LUCZKO”
ul. Królewskiej Tamy
44-100 Gliwice
skr. poczt. 155



www.luczko.pl
ppuluczko@interia.pl

Rok założenia 1993

HANDLE FOR RAILWAY RAILS

The handle can be used for lifting and transportation of following types of railway rails: S49, R50, S54, UIC54, UIC60. A single handle is recommended for transportation of only short sections of rails that are stable. Longer sections should be transported on at least two grippers mounted on the traverse.

The clamping on the rail is self-acting during the lifting

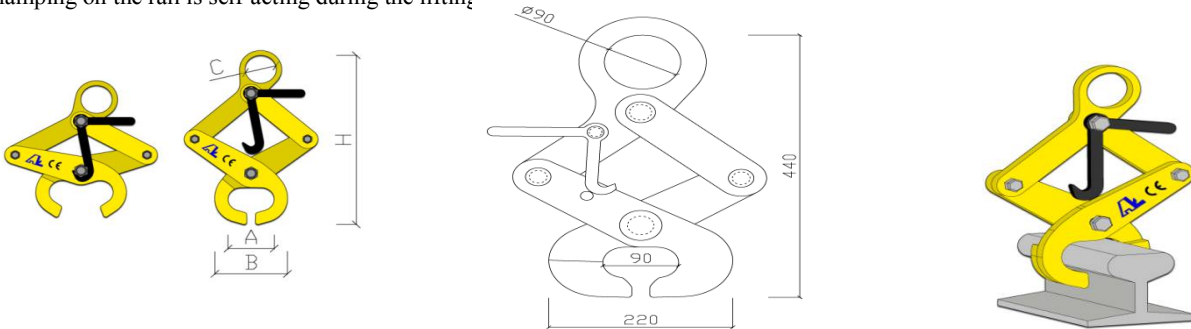

TYPE	A [mm]	B [mm]	C [mm]	H [mm]	WEIGHT [kg]
SZ -0,5	90	170	36	340	4,2
SZ -1,0	90	190	50	360	8,5
SZ -2,0	90	210	80	400	11,4
SZ - 5,0	90	220	90	440	27,0

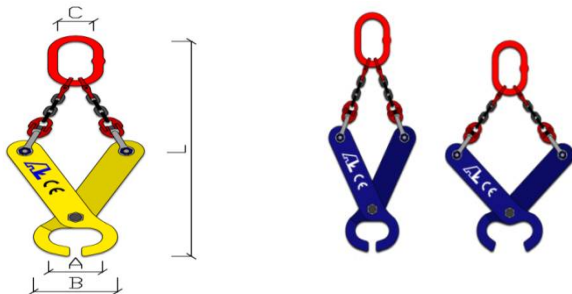

DOR [kg]	A [mm]	L [mm]	C [mm]	Weight [kg]
1 250	87	598	60	9

CERTIFIED PRODUCTS



TRAVERSERS FOR MOVING RAILWAY UNITS

It is intended for lifting, loading, stacking and dismantling railway ties. The parts can be build from concrete, wood or be pre-stressed.

DOR (Permissible Workload): 2000 kg

Traverse dimensions: 1560x1800mm.

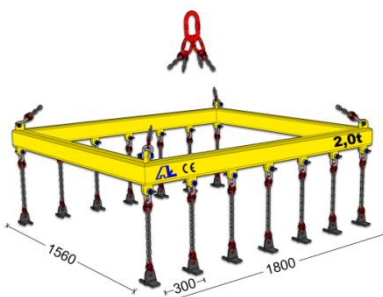

The grip has two ends: straight and smooth, designed for carrying wooded ties and with pins for concrete ties..



WE ALSO OFFER OTHER HANDLES AND TRAVERSE ACCORDING TO THE INDIVIDUAL NEEDS OF OUR CUSTOMERS!